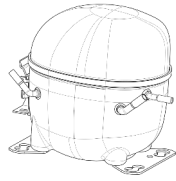

220-240V 50 1~

**GENERAL DATA**

**Application:** LBP  
**Refrigerant:** R404A  
**Evaporating Temperature Range:** -40°C to -10°C  
**Compressor Cooling:** Fan  
**Fan air flow:** 520 m<sup>3</sup>/h  
**Type:** Hermetic reciprocating  
**Technology Type:** On-Off  
**Expansion Device:** Capillary Tube or Expansion Valve  
**Packing Quantity:** Single - 1 pc  
**Displacement:** 14.28 cm<sup>3</sup>  
**Horse power:** 3.4 hp

Approvals:    

**MECHANICAL DATA**

**Bore:** 30.16 mm  
**Stroke:** 20 mm  
**Oil Charge:** 350ml +/-15ml  
**Free Internal Volume:** 2.1 cm<sup>3</sup>  
**Maximum Recommended Refrigerant Charge:** 350 g  
**Oil Type Configuration:** Polyolester  
**Oil Type Viscosity:** ISO22  
**Compressor pressurization:** Dry air charge  
**Weight:** 11.8 kg

**ELECTRICAL DATA**

**Motor Type:** CSIR  
**Starting Torque:** HST  
**Voltage working range at 50 Hz:** 198-254 V  
**Maximum Motor Temperature:** 130 °C  
**Start Winding Resistance:** 13.91 Ω (± 10%) at 25°C  
**Run Winding Resistance:** 4.48 Ω (± 10%) at 25°C  
**Locked Rotor Amperage (LRA):** 22 A

**MOUNTING ACCESSORIES**

	Description	Code
<b>Anchorage:</b>	no	-
<b>Capacitor Bracket:</b>	no	-
<b>Washer:</b>	no	-
<b>Pin:</b>	no	-
<b>Clip:</b>	no	-
<b>Rotolock valve:</b>	no	-
<b>Cover:</b>	yes	2075282
<b>Grommets:</b>	yes	2221011
<b>Sleeves:</b>	yes	2222018
<b>Terminal Board:</b>	yes	1027060
<b>Overload Protector Bracket:</b>	yes	2075299

**ELECTRICAL COMPONENTS**

	Component type	Description	Code
<b>Starting Device:</b>	Current relay	MTRPH-0055-65	2334148
<b>Motor Protection:</b>	External 3/4"	MST26ALK-3259	2319147
<b>Start Capacitor:</b>		88-108 MFD 330V	2252348

**EXTERNAL CHARACTERISTICS**

**Base Plate:** European  
**Tray Holder:** No  
**Height:** 206 mm

	Internal Diameter (mm)	Material	Shape
<b>Suction Connector</b>	8.1	Copper	Slanted 42°
<b>Discharge Connector</b>	6.1	Copper	Straight



**RATED POINT DATA**

Cooling Capacity (W)	Power Consumption (W)	Current Consumption (A)	Gas Flow Rate (kg/h)	Efficiency (W/W)
±5%	±5%	±5%	±5%	±7%
413	380	2.63	10.37	1.09

Test condition: EN 12900, Fan, Return Gas 20°C, Subcooling 0K, Evaporating: -35°C, Condensing: 40°C, Ambient: 35°C

**PERFORMANCE CURVE DATA**

**220V 50Hz**

Condensing Temperature (°C)	Evaporating Temperature (°C)	Cooling Capacity (W)	Power Consumption (W)	Current Consumption (A)	Gas Flow Rate (kg/h)	Efficiency (W/W)
		±5%	±5%	±5%	±5%	±7%
<b>35°C</b>	-10	1 444	669	3.72	35.21	2.16
	-15	1 185	606	3.45	28.68	1.96
	-20	957	544	3.21	22.99	1.76
	-25	758	485	2.99	18.13	1.56
	-30	590	428	2.79	14.05	1.38
	-35	453	372	2.61	10.75	1.22
	-40	345	319	2.46	8.19	1.08

Condensing Temperature (°C)	Evaporating Temperature (°C)	Cooling Capacity (W)	Power Consumption (W)	Current Consumption (A)	Gas Flow Rate (kg/h)	Efficiency (W/W)
		±5%	±5%	±5%	±5%	±7%
<b>45°C</b>	-10	1 213	747	4.05	33.33	1.62
	-15	1 001	667	3.70	27.28	1.50
	-20	810	591	3.39	21.94	1.37
	-25	642	519	3.11	17.29	1.24
	-30	496	451	2.86	13.30	1.10
	-35	372	386	2.65	9.94	0.96

Condensing Temperature (°C)	Evaporating Temperature (°C)	Cooling Capacity (W)	Power Consumption (W)	Current Consumption (A)	Gas Flow Rate (kg/h)	Efficiency (W/W)
		±5%	±5%	±5%	±5%	±7%
<b>55°C</b>	-10	982	826	4.38	31.35	1.19
	-15	814	728	3.95	25.76	1.12
	-20	661	636	3.56	20.75	1.04
	-25	523	549	3.22	16.28	0.95
	-30	398	469	2.93	12.35	0.85

Test condition: EN 12900, Fan, Return Gas 20°C, Subcooling 0K, Ambient: 35°C

**ASSEMBLY INSTRUCTION**

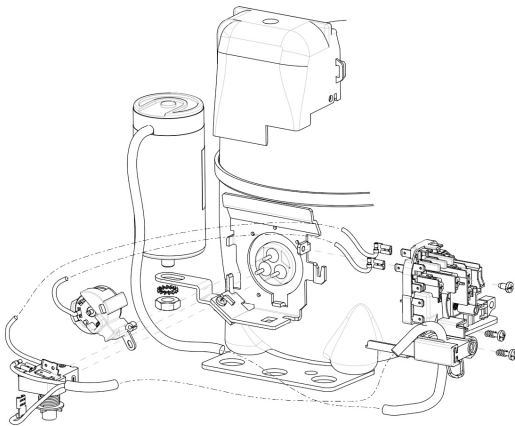

**WIRING DIAGRAM**

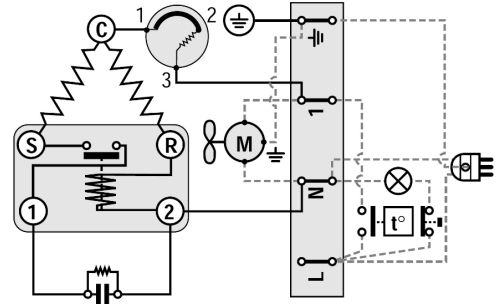

**OPERATING ENVELOPE**

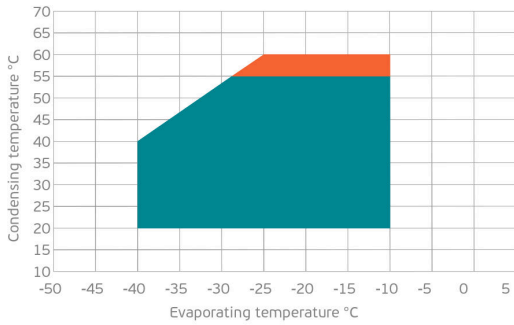

- Operating Condition
- Transient Condition
- Superheating

**NOTE:** usage of compressors outside of intended working range cannot make use of the warranty, or should be consulted with Technical support.

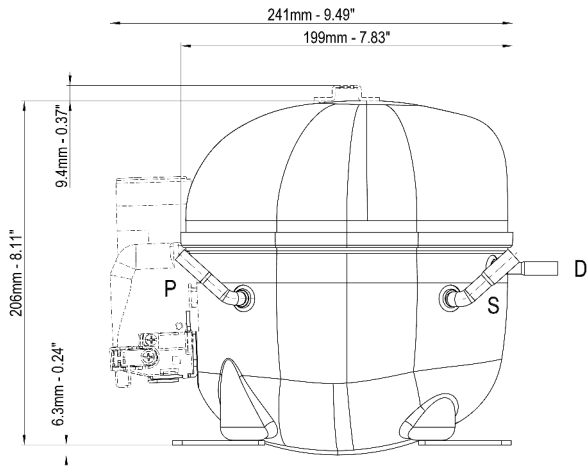

	∅ mm	∅ in	Material
<b>S - Suction</b>	8.10 - 8.20	0.32	Cu
<b>P - Process</b>	6.10 - 6.20	0.24	Cu
<b>D - Discharge</b>	6.10 - 6.20	0.24	Cu

